

Cantilever Leg & Rails

(Suits Anvil & Cubit System)

Assembly Instructions

Tools Required: Powered Screwdriver



Cantilever Leg & Rails (Suits Anvil & Cubit System)

Assembly Instructions

Thank you for purchasing Knight product, please carefully read the assembly instructions prior to installment to gain a complete understanding of the product. It provides you with important information about the safety, use, installation and maintenance.

WARNING: FAILURE TO COMPLY WITH OR OBSERVE ALL ASSEMBLY, SAFETY AND OPERATION INSTRUCTIONS REGARDING THE USE OF THIS PRODUCT MAY RESULT IN SERIOUS BODILY INJURY.

SAFETY

- The product must be used in a safe manner. Inappropriate use may cause damage to the product and/or cause bodily harm to the user or persons nearby.
- Don't locate furniture in direct sunlight or near air-conditioning inlet or heating radiator.
- Don't put high-temperature or frozen objects on furniture.
- Safely carry product to location of assembly.
- Retain this operation manual and pass it on to any future owner.

SET UP AND INSTALLATION

- Assemble the product according to the assembly instructions.
- To prevent possible scratches or damage, assemble the product on a soft surface such as a blanket, carpet or packaging.
- Place the product a safe distance from window frames, radiators, furniture etc. so that persons cannot become trapped.

It is recommended that this product is assembled by 2 people.

Any questions contact Knight on 0800 143 143

Due to continuous improvement of our products, our assembly instructions may not be in complete accordance with the product and we apologise in advance.



Please note these assembly instructions apply to both Anvil and Cubit System.

Cantilever Leg & Rails (Suits Anvil & Cubit System)

Assembly Instructions

Parts

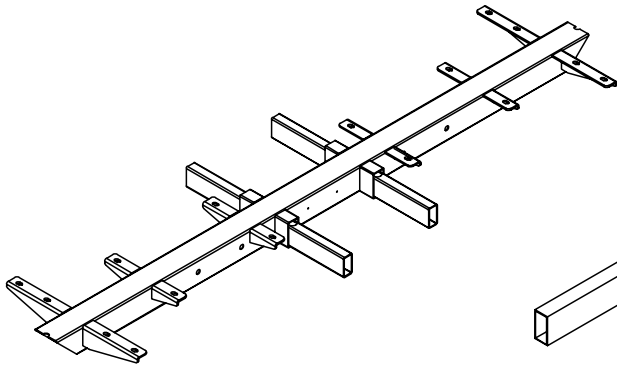

1 x Cantilever Frame

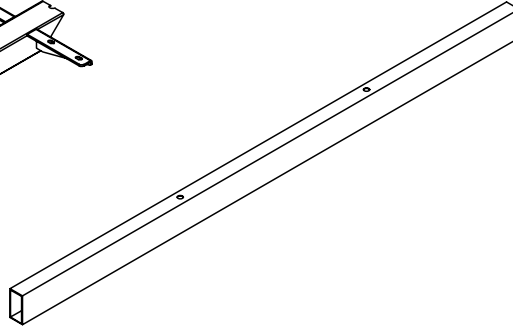

2 x Rails

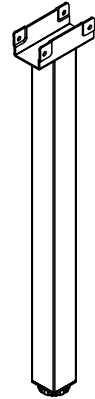

2 x Cantilever Leg

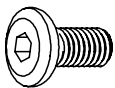

8 x M6x12

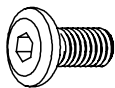

8 x M8x16

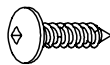

18 x ST5x23



4 x ST5x70

Tools



Electric Driver
Square



Allen Key

Step 1

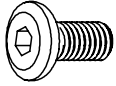

8 x M6x12

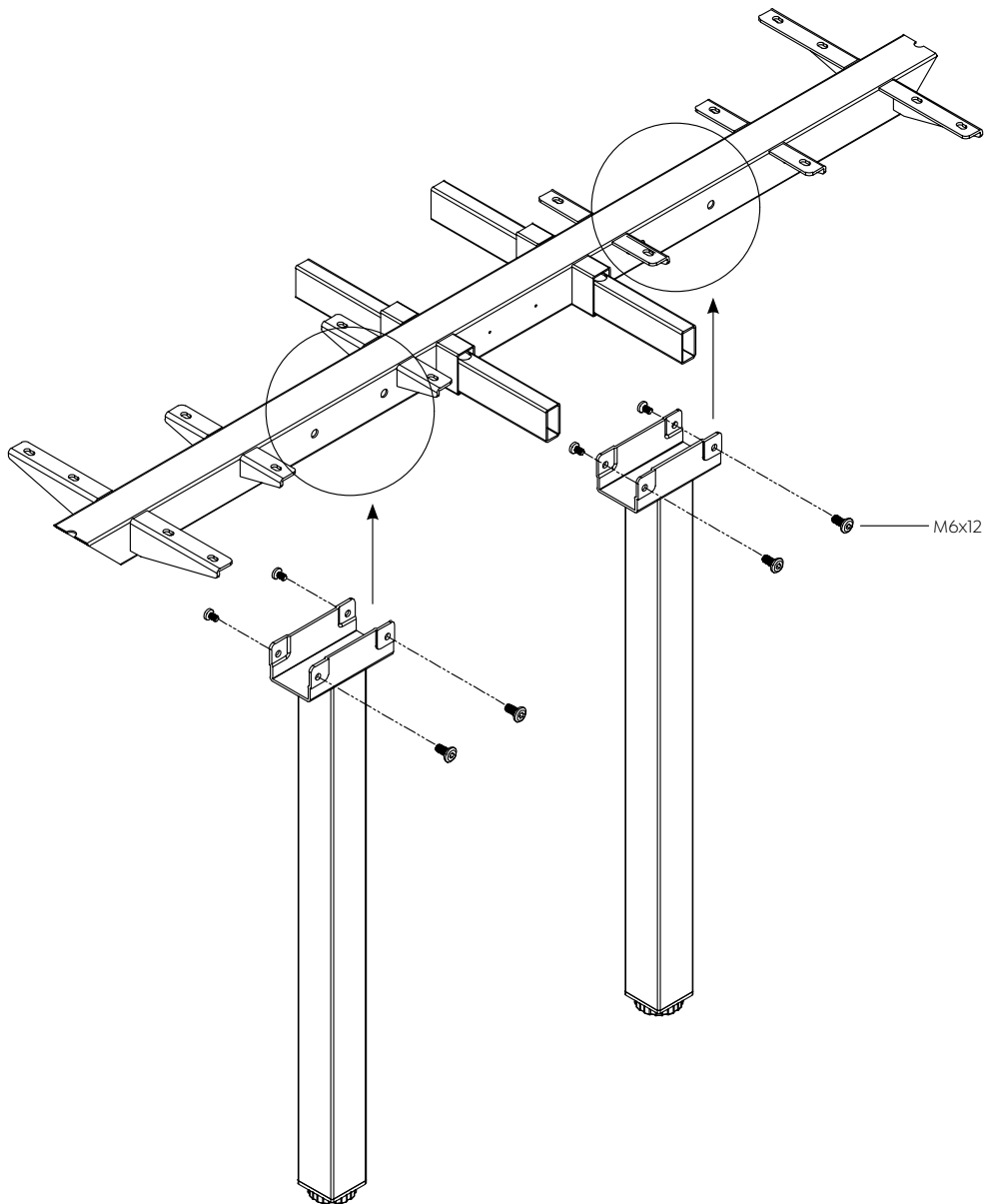

Step 2

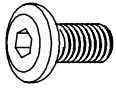

8 x M8x16

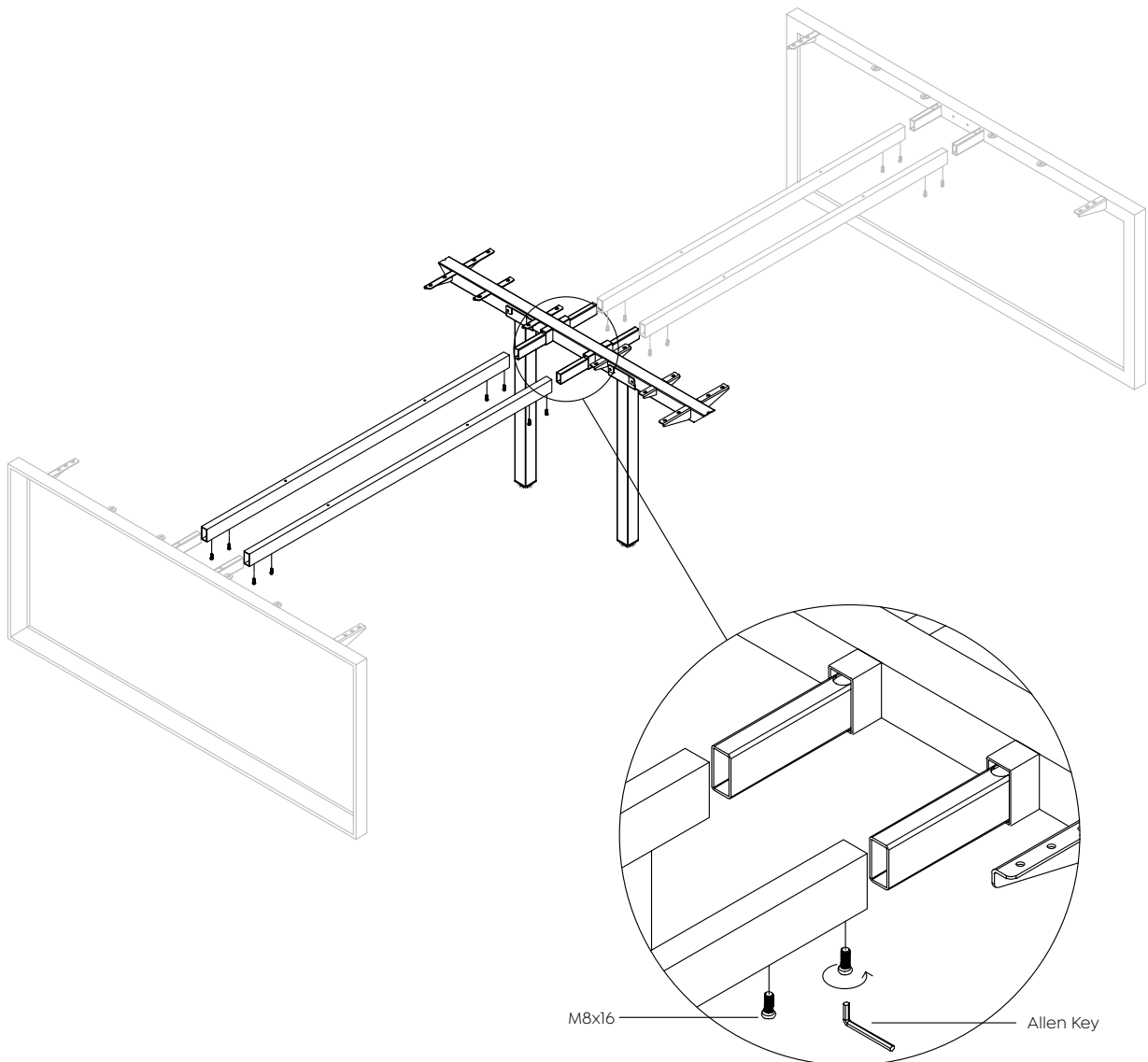

Step 2

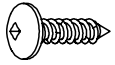

18 x ST5x23



4 x ST5x70

Worktop Alignment with Frame:

Please note when installing the worktops, they will need to over hang at the front by 5mm to allow for the screen bracket gap of 10mm between the two worktops.

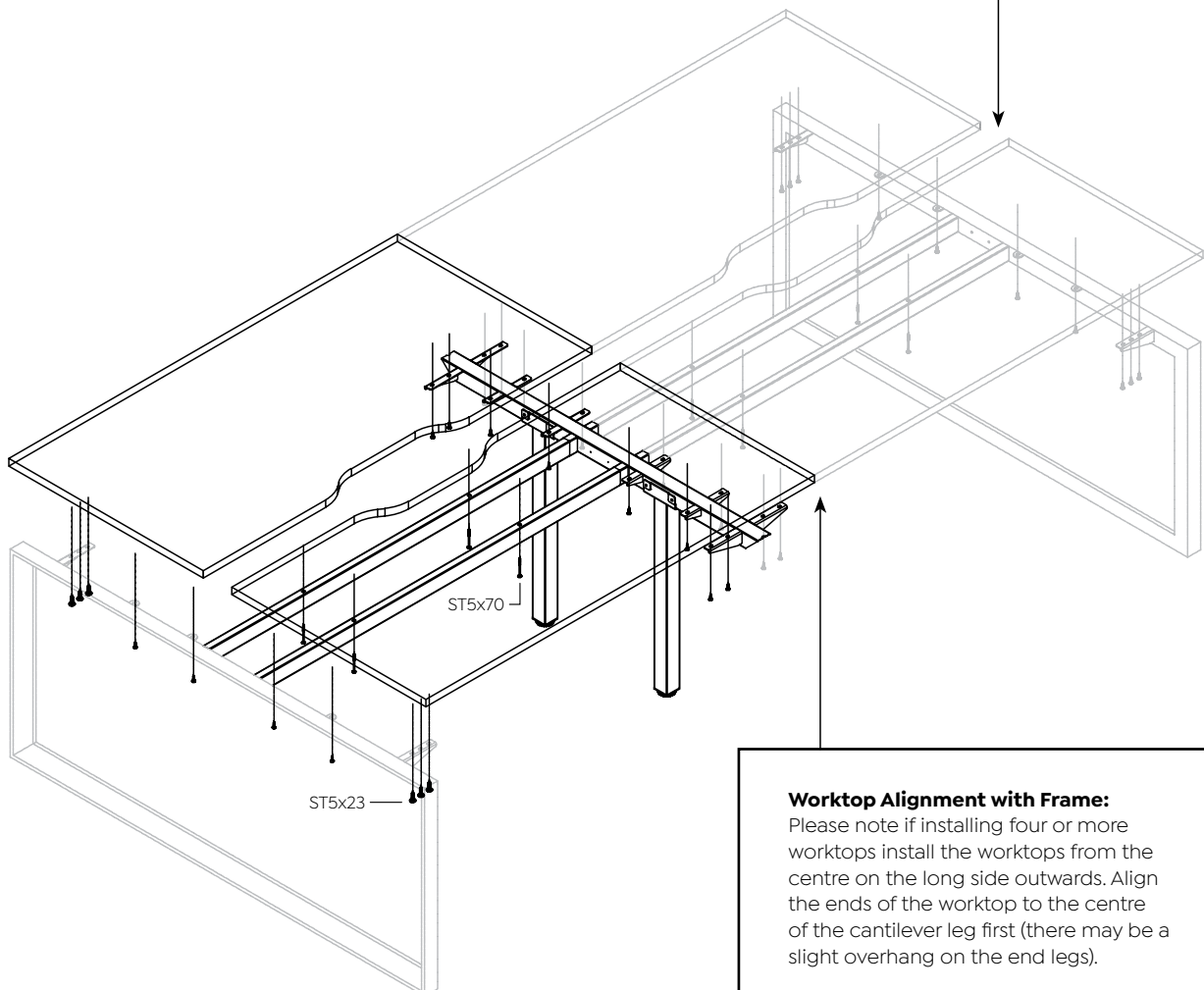

Complete

