

# Cubit Locker - 2 Door

## Assembly Guide



**Need a hand?**

Contact us at [info@knightgroup.co.nz](mailto:info@knightgroup.co.nz) or 0800 143 143 for assistance.

# Thank you for purchasing Knight product.

**Please carefully read the assembly instructions prior to installment to gain a complete understanding of the product. It provides you with important information about the safety, use, installation and maintenance.**

WARNING: FAILURE TO COMPLY WITH OR OBSERVE ALL ASSEMBLY, SAFETY AND OPERATION INSTRUCTIONS REGARDING THE USE OF THIS PRODUCT MAY RESULT IN SERIOUS BODILY INJURY.

## **Safety**

- The product must be used in a safe manner. Inappropriate use may cause damage to the product and/or cause bodily harm to the user or persons nearby.
- Don't locate furniture in direct sunlight or near air-conditioning inlet or heating radiator.
- Don't put high-temperature or frozen objects on furniture.
- Safely carry product to location of assembly.
- Retain this operation manual and pass it on to any future owner.

## **Set Up and Installation**

- Assemble the product according to the assembly instructions.
- To prevent possible scratches or damage, assemble the product on a soft surface such as a blanket, carpet or packaging.
- Place the product a safe distance from window frames, radiators, furniture etc. so that persons cannot become trapped.

**Any questions contact Knight on 0800 143 143**

Due to continuous improvement of our products, our assembly instructions may not be in complete accordance with the product and we apologise in advance.

**Tools Required:** Powered Screwdriver

# Parts

<b>A</b>	Top Panel	1
<b>G</b>	Bottom	1
<b>X</b>	Left Side Panel	1
<b>Z</b>	Right Side Panel	1
<b>O</b>	Batten	1
<b>V</b>	Door Panel	2
<b>F</b>	Fixed Shelf	1
<b>D</b>	Back Panel	1

<b>c1</b>	6*35 Cam bolt	30
<b>d1</b>	8*30 Dowel Pin	28
<b>c2</b>	Cam Cover	30
<b>h2</b>	Hanger Holder	4
<b>s1</b>	4*16 Screw	52
<b>h1</b>	Hinge	4
<b>L1</b>	Lock	2
<b>L2</b>	Lock Catch	2

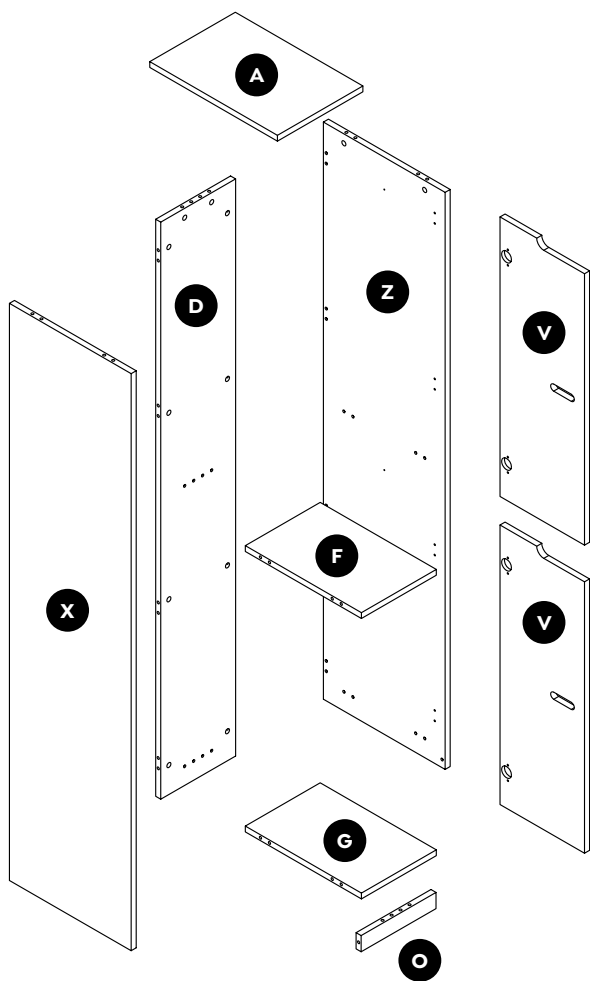

# Step 1

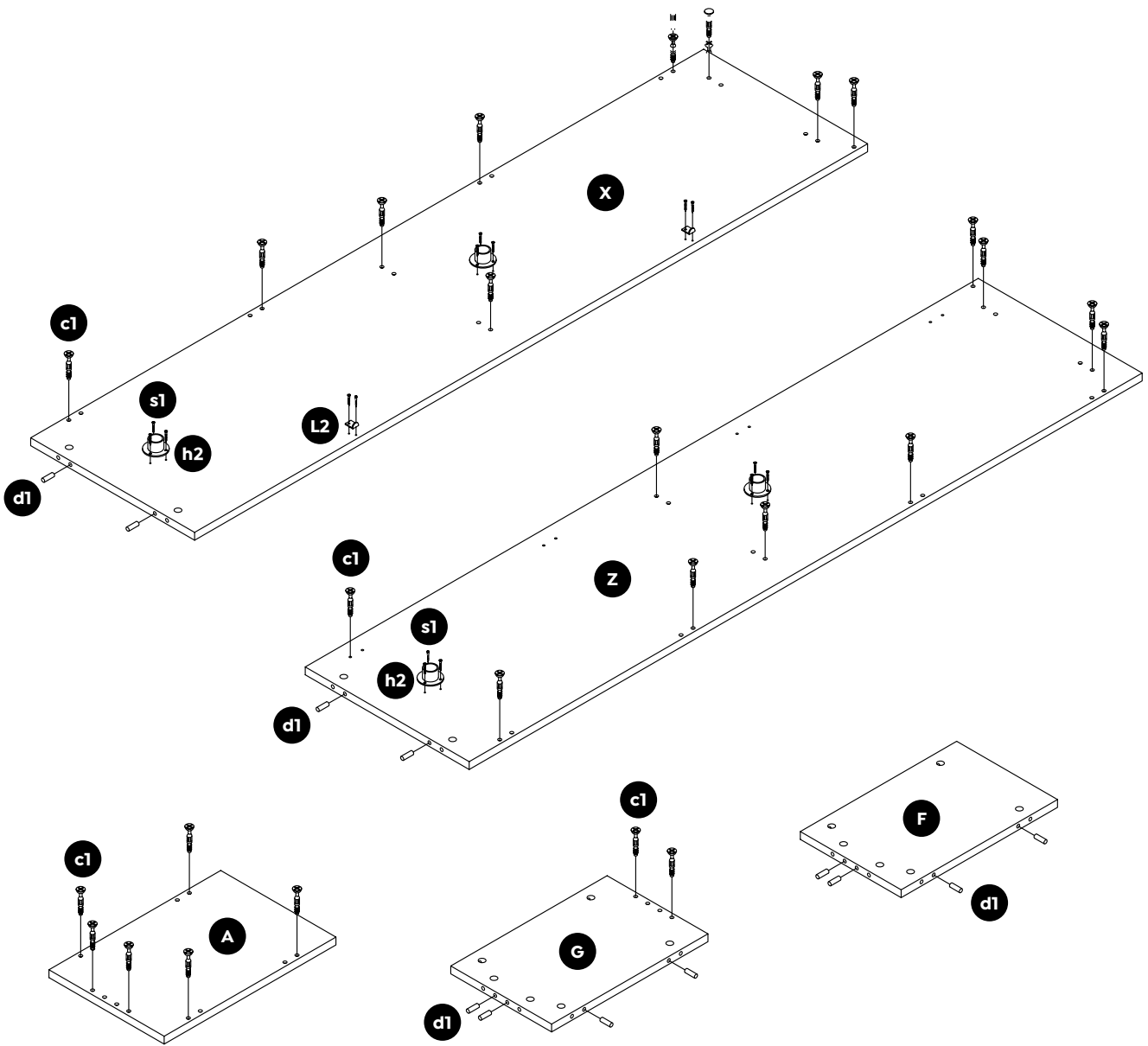

## Preparation for Panels X, Z, F, A, G

1. Insert cam bolts **c1** into panel **X**, **Z**, **A** and **G**.
2. Insert dowel pins **d1** into panels **F**, **X**, **Z** and **G**.
3. Fix lock catch **L2** to panel **X** with screw **s1**.
4. Fix clothes holder **h2** to panel **X** and **Z** with screw **s1**.

## Step 2

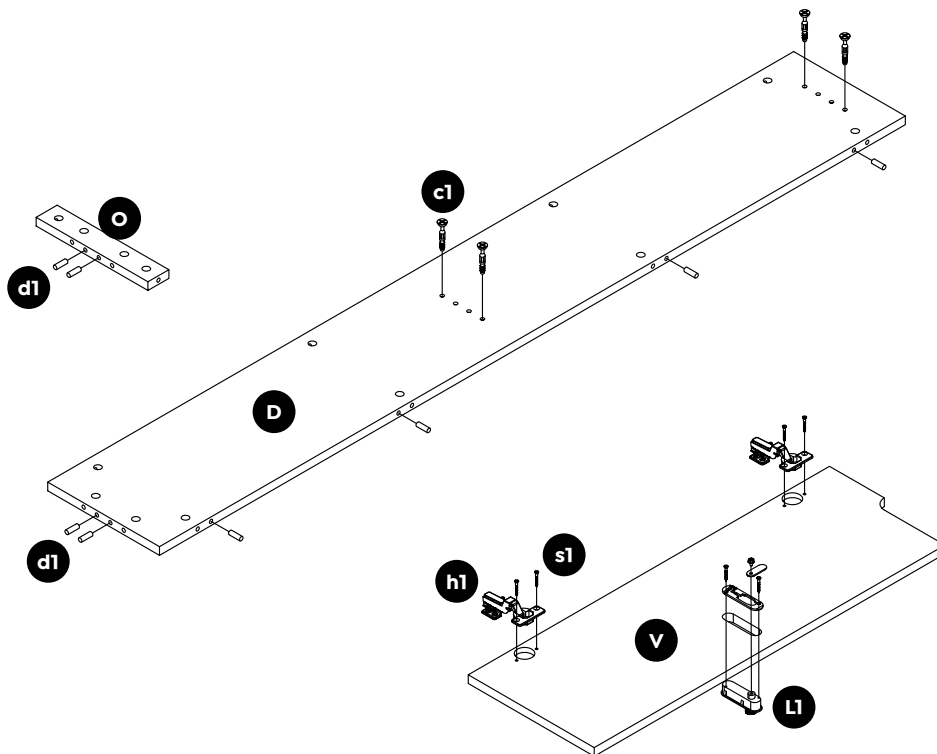

### Preparation for Panels V, O, D

1. Insert cam bolts **c1** into panel **D**.
2. Insert dowel pins **d1** into panels **D** and **O**.
3. Fix lock **L1** to panel **V** with screw **3.5\*20**.
4. Fix hinge bodies **h1** to panel **V** with screws **s1**.

## Step 3

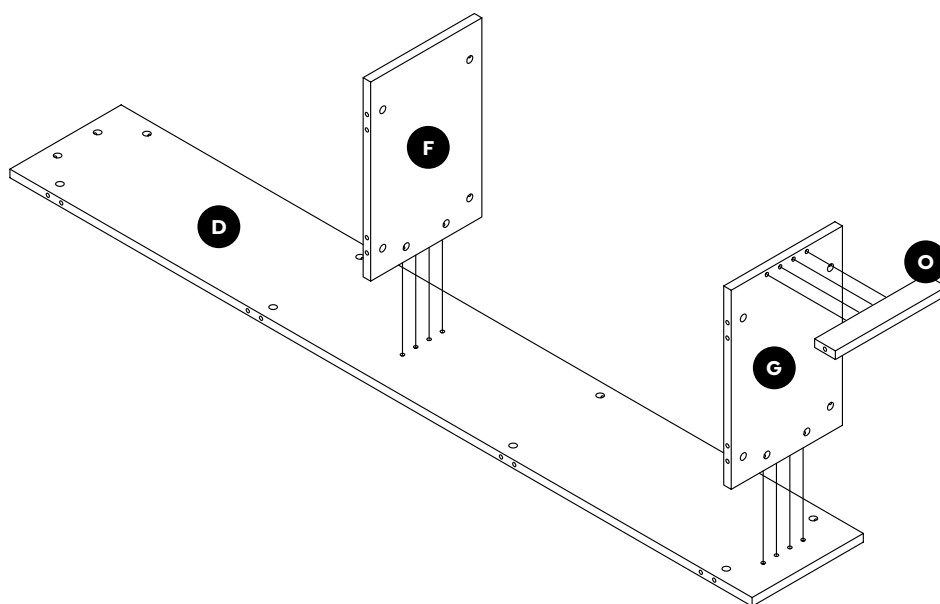

### Panel F, G and D assembly

1. Insert cam bolts **c1** on panel **O** into cams on panels **G** and tighten in a clockwise direction.
2. Insert cam bolts **c1** on panel **F** and **G** into cams on panels **D** and tighten in a clockwise direction.

# Step 4

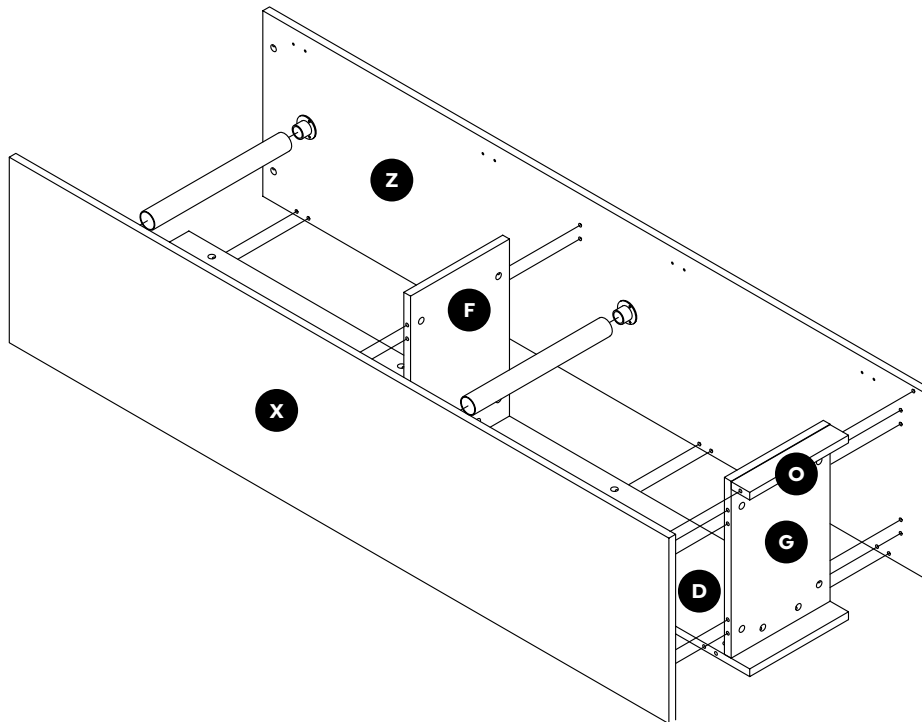

## Panel X and Z assembly

1. Insert cam bolts **c1** on panel **X** and **Z** into cams on panels **O**, **G**, **F** and **D** and tighten in a clockwise direction.
2. Put the clothes hanger into the hanger holder **h2**.

## Step 5

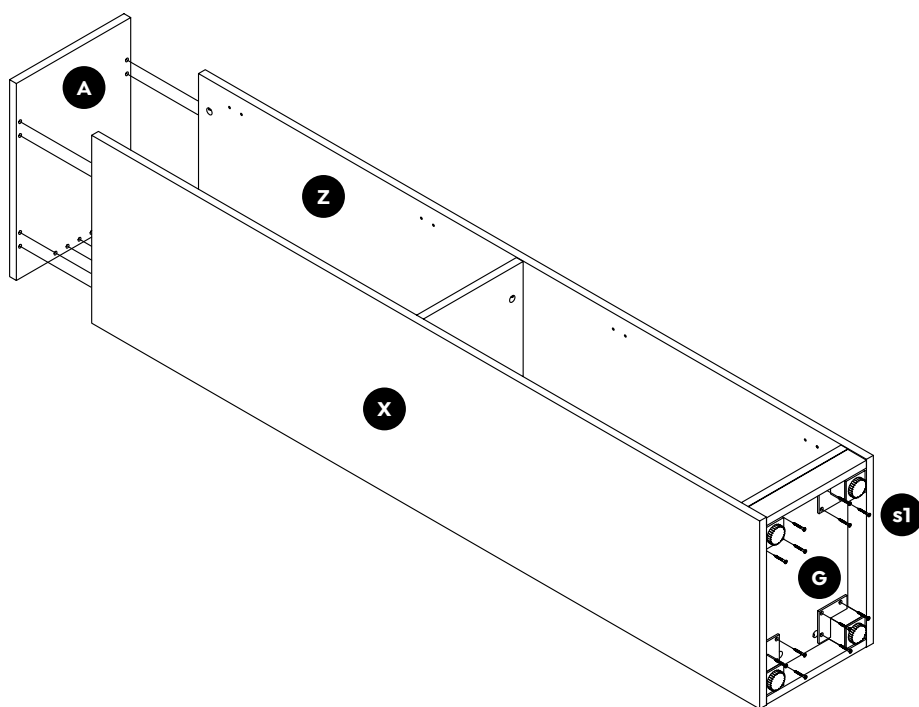

### Panel A assembly

1. Insert cam bolts **c1** on panel **A** into cams on panels **X**, **Z** and **D** and tighten in a clockwise direction.
2. Fix adjustable foot to panel **G** with screws **s1**.



# Step 6

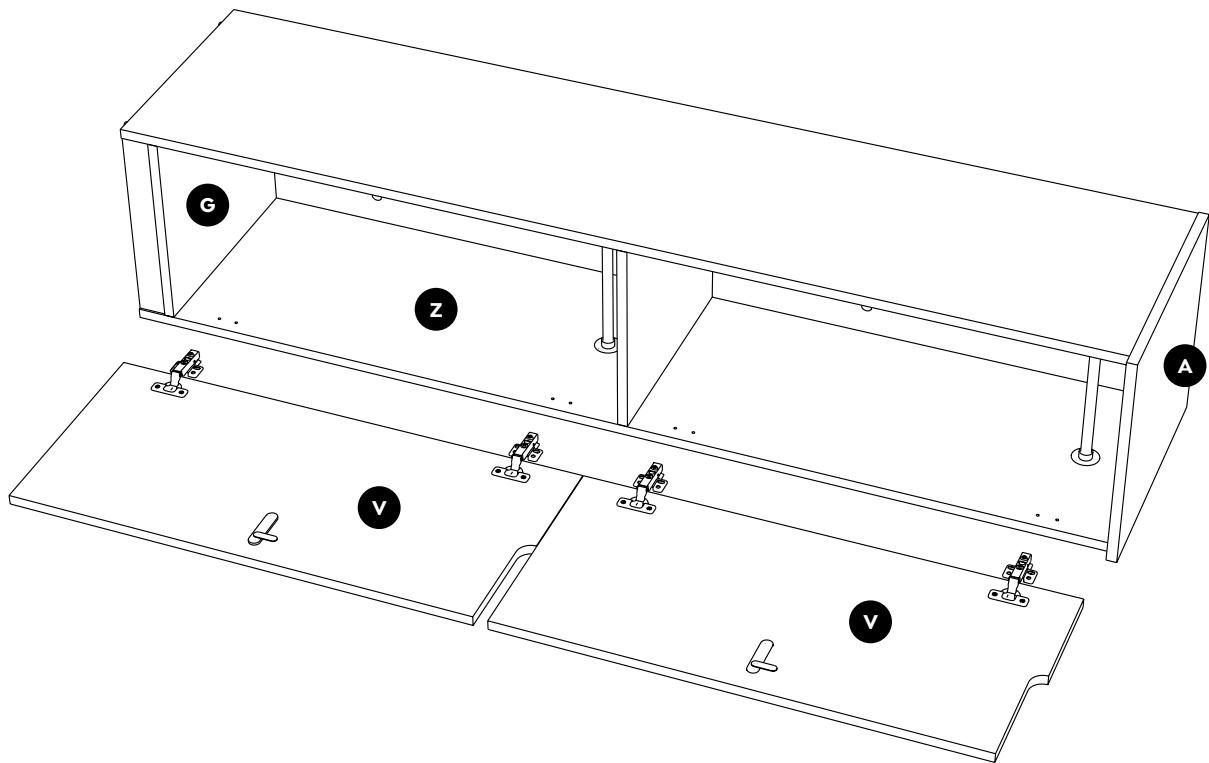

## Door panel V assembly with hinge h1

Please note we recommended lying the locker unit on the floor with panel Z on the floor to install the doors and hinges.

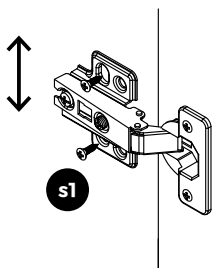

Fix the screws **s1** into the predrilled hole shown above, and then adjust the door panel upward and downward to the correct location.

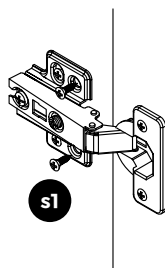

Fix the additional screws **s1** to the panel to consolidate the hinge shown above.

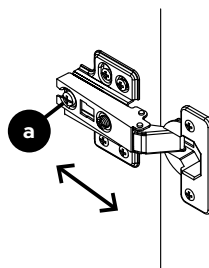

Loosen the screw **a** to adjust the forward and backward movement of the door panel to the correct location, and then tighten the screw **a**.

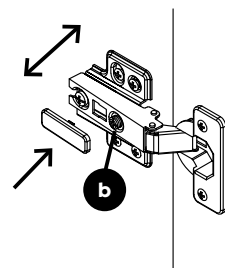

Loosen the screw **b** to adjust the left and right movement of the door panel to the correct location, and finally cover the hinge with the cap.

# Lock Operating Instructions

**Change factory code or reset code when the lock is in open position (Key NOT Required)**



1. The preset factory code is 0-0-0-0. To change the code, rotate the knob to open position.



2. The new code can be reset, eg. 1-1-1-1.



3. Rotate the knob back to the closed position to complete the process.

**Forgotten your code? Recover code when the lock is in closed position (Key Required)**



1. Insert the key into the knob and turn the key to the open position.



2. Turn each of the dials individually until they cannot move to recover the forgotten code.



3. Turn the key to the close position and pull the key out. The lock can now be used normally.

# Care & Maintenance

Proper care and maintenance are crucial for extending the lifespan of your melamine furniture. Below are some essential tips to keep in mind when caring for your melamine furniture:

## General Cleaning

Clean surfaces regularly by wiping them down with a soft damp cloth and a general-purpose cleaner or detergent. For best results, use a streak-free glass cleaner.

Important: Always wipe with a damp cloth first, followed by a dry cloth to remove moisture after cleaning.

## Wipe Up Spills Immediately

Avoid exposing melamine surfaces to high or continuous levels of moisture, steam, and humidity. It is essential to wipe up spills immediately to prevent them from seeping into the material and causing damage.

## Stain Removal

If you encounter a stain on your melamine furniture, the first step is to use a mild household spray and wipe the surface with a soft cloth. Don't rub too hard, as this can damage the surface. Dry the surface using a soft cloth to ensure no residue remains.

For stubborn marks or stains:

- Apply Handy Andy or diluted Janola (1 part to 3 parts water), then wipe down with a warm damp cloth.
- For smearing, fingerprints, or marks from cold or hot dishes: Apply 1 or 2 applications of acetone (available at pharmacies) and wipe over with a dry cloth.
- For felt pen or dry marker stains: Use methylated spirits or acetone.
- For paint stains: Use acetone or thinners (available at paint shops).
- For contact glue: Use Ados Solvent N (available at paint shops).

Follow up with streak-free glass cleaner to remove any residue.

## Avoid Using Certain Cleaning Products

To ensure you do not void the warranty of your melamine furniture, avoid using commercial cleaning products, abrasive cleaners, scouring pads or abrasive papers. Do not use citrus-based cleaners, as they may cause damage and leave a sticky residue on the surface.

## Protect Structural Integrity

Your furniture has been carefully made and should also be treated with care. If you need to move furniture, ensure that you lift and carry the furniture rather than drag it across the floor. Dragging furniture exerts pressure on its joints and connections, causing harm to its structural integrity. If your furniture is damaged due to dragging, your warranty may become void.

## Conclusion

Melamine furniture is a durable and versatile material that requires proper care and maintenance to ensure longevity. By following the tips outlined above, you can maintain the quality of your melamine furniture and enjoy it for many years to come.

**0800 143 143**  
info@knightgroup.co.nz

**knightgroup.co.nz**

